

MILCOTS™ 15" LCD monitor / 5115XG

Product range, for harsh environments



5115XG model

for waterproof mounting

Naval Consoles

Offshore Applications

Shelters and Vehicles

Railway

Anti-Vandalism Display

Key points

- High quality display (high contrast ratio)
- Lock / cancel OSD
- Remote control
- Non-reflective coated glass, optical quality 92%
- Typical product availability: 8 to 10 years

Options

- Adapted non-reflective coated glass available on request
- Brightness tuning from 100 to 5% (dimming)
- On-site backlight replacement
- Water-resistant housing
- Handles
- TV input
- EMC/EMI. This range is available with several levels of protection and reinforcement from the standards required by the information technology industry to the military sector (MIL-STD)

For operations in extreme conditions (shock, vibration, waterfall, sea fog, very high or low ambient light conditions), MILCOTS's 5000 series displays is the right choice for field applications (ground, sea, railway transport), aboard vehicles or in shelter)

5000 series displays are available in:

15" XGA
17", 18", 19" and 20" SXGA
20", 21" and 23" UXGA
24" WUXGA.

with custom packaging for field applications

15" LCD monitor / 5115XG

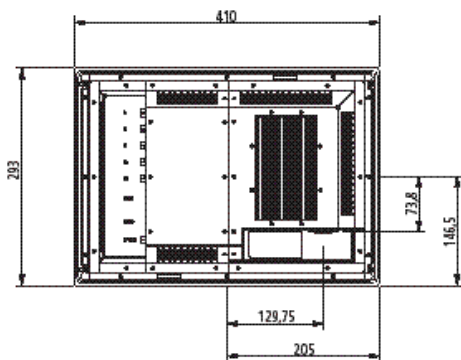
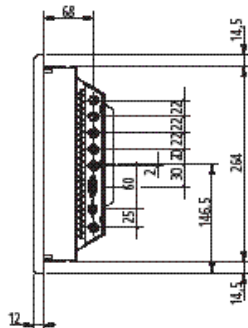
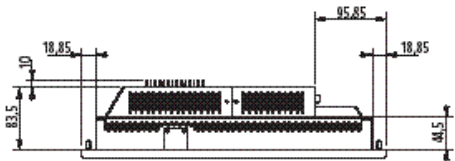
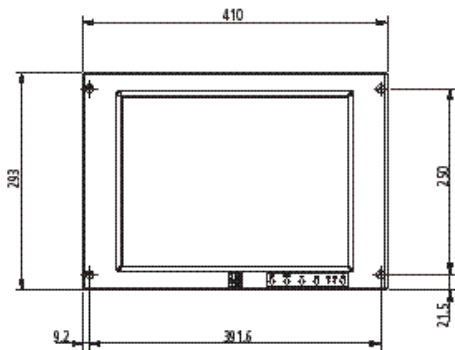

Display module
 Resolution : 1024 x 768
 Brightness : 250 cd/m2
 Contrast ratio : 500:1
 Dot pitch : 0,294 mm
 Viewing angle : 170°/170°
 Response time : 15 msec
 Display color : 16.7M
 Active display area : 386,4 mm x 289,8 mm

Input signals
 Connectors : BNC
 Analogic : RGB 0,7Vp-p / 75 Ohms
 Synchronisation : H/V separated (TTL) - composite - sync on green
 Synchronisation range : H : 30 KHz to 100 KHz - V : 50 Hz to 70 Hz

Controls
 On Screen Display: waterproof front panel keyboard
 Remote control: 1 RS232 port

Physical Features
 Monitor dimensions : 410 mm (W) x 293 mm (H) x 105,5 mm (D)
 Monitor weight : 7,1 kg
 Standard color : RAL 101 (black)

Electrical Features (5115XG-1A model)
 Power consumption : 20 W

Environmental Conditions
 Operating temperature : 0°C to +50°C
 Storage temperature : -30°C to +70°C
 Humidity : 10% to 85%
 Altitude : 0 to 45000 feet
 Shock : 30 G, 11 ms
 Vibration : MIL STD 810E
 Non-reflective coating glass : 92%
 Front panel protection : NEMA 4

Standard configurations

5115XG-XX Models	Standard	MIL-STD-461
12 Vdc input on HE308 connector external power supply non delivered	0A	
12 Vdc input on lockable connector external power supply 12 Vdc / 70 W / 115-230 Vac / 50-60 Hz	1A	
115-230 Vac input /50-60 Hz on HE308 connector	2A	
115-230 Vac input /40-400 Hz / 170 Vdc on HE308 connector	3A	3D
18-36 Vdc input on HE308 connector	4A	

configurations are fitted out with a 92% non-reflective coating glass.
 Others are fitted out with reinforced glass.

Options
 TV input (C-VBS) : 1 additional BNC connector
 TV input (S-VHS) : 1 additional mini-DIN connector
 Backlight : on site backlight replacement

Customization
 touch input device (contact us)
 DVI input
 IP63 aluminum casing

Warranty : 1 year (expandable to 3 and 5 years)